

2. Circling Magnets

Sergej Faletič

University of Ljubljana, Faculty of Mathematics and
Physics
Slovenia

The phenomenon

- <https://www.youtube.com/watch?v=eYtMDHZG8AY>

The qualitative explanation

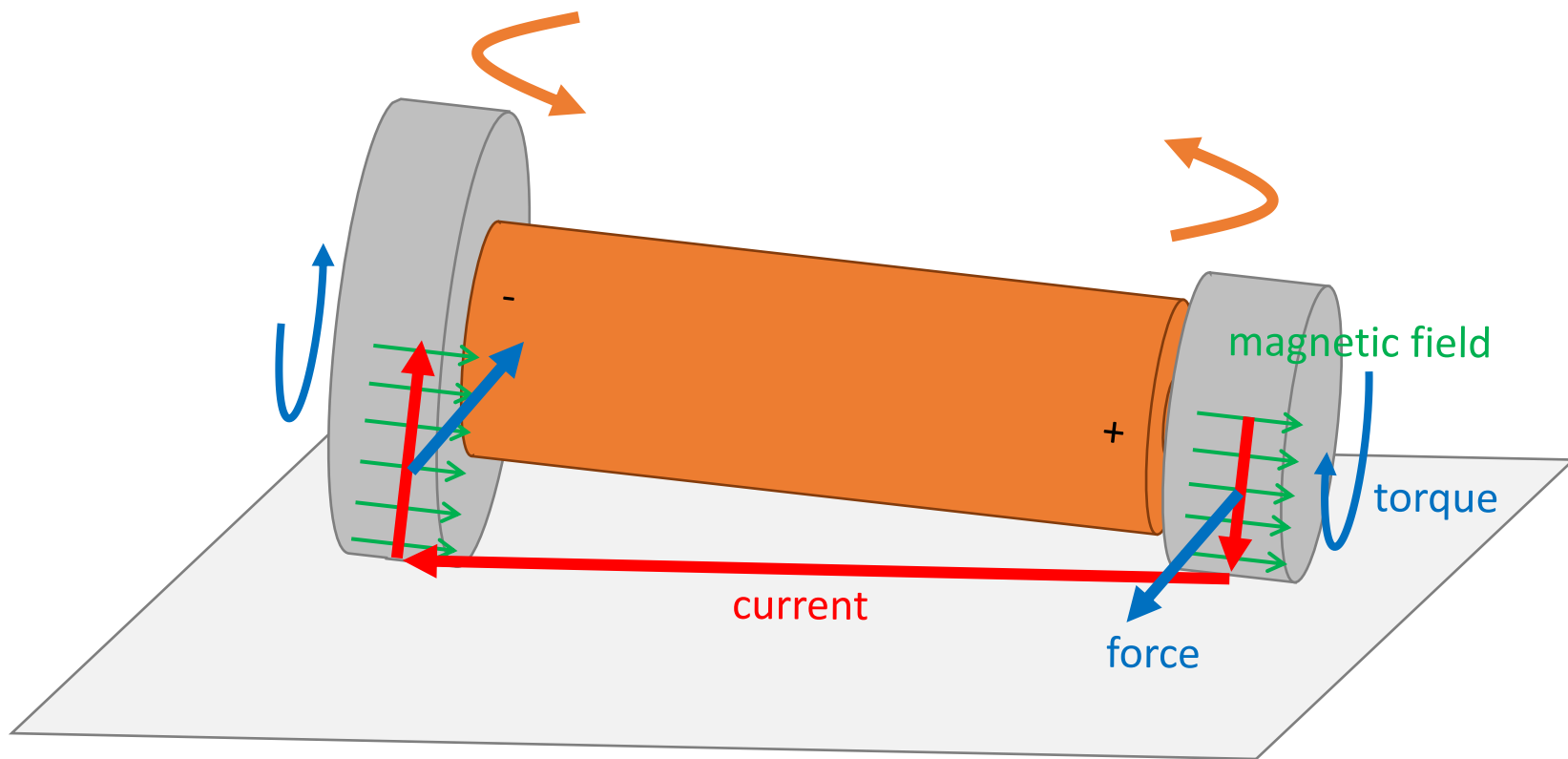

The qualitative explanation

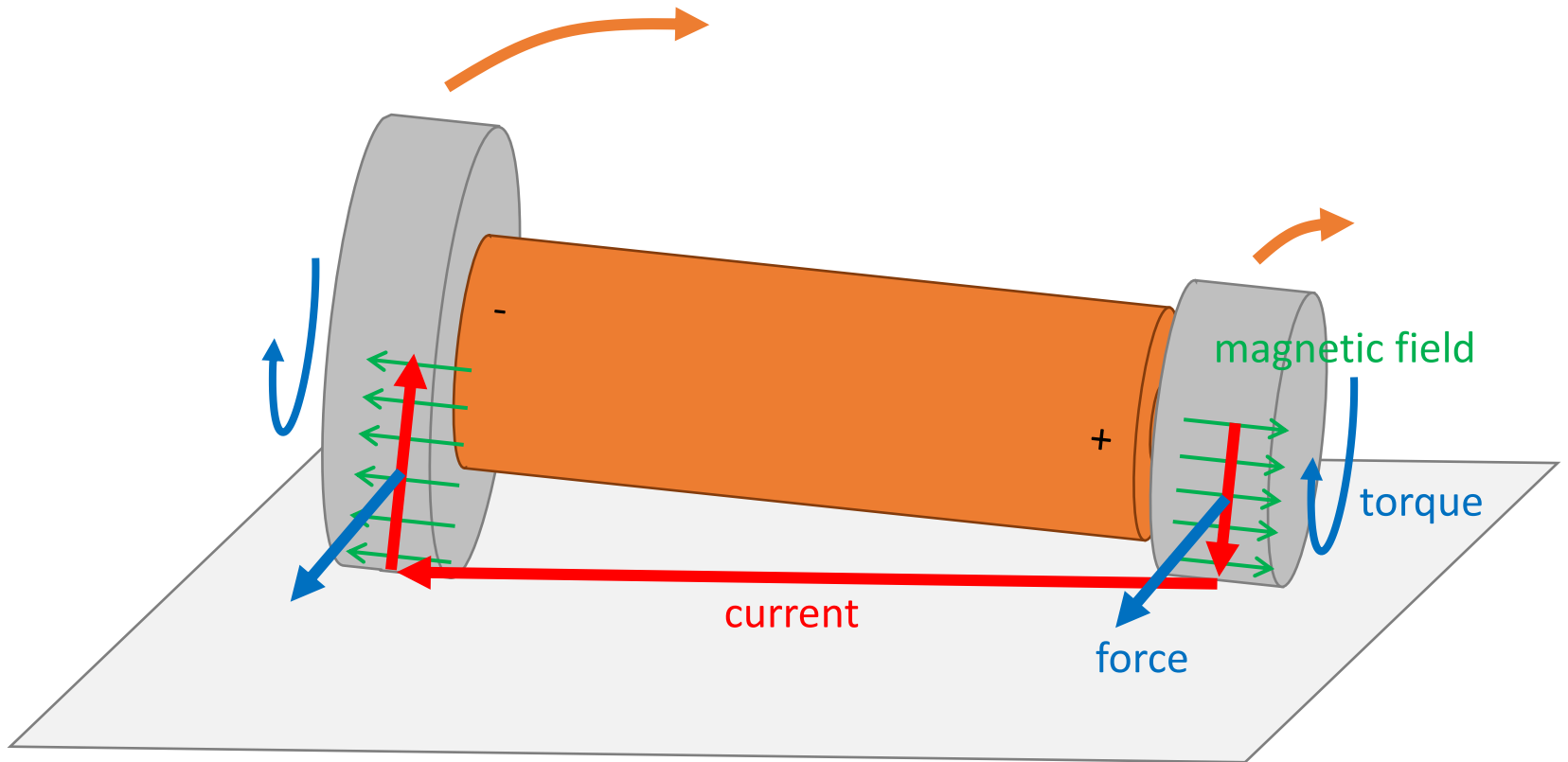

The qualitative explanation

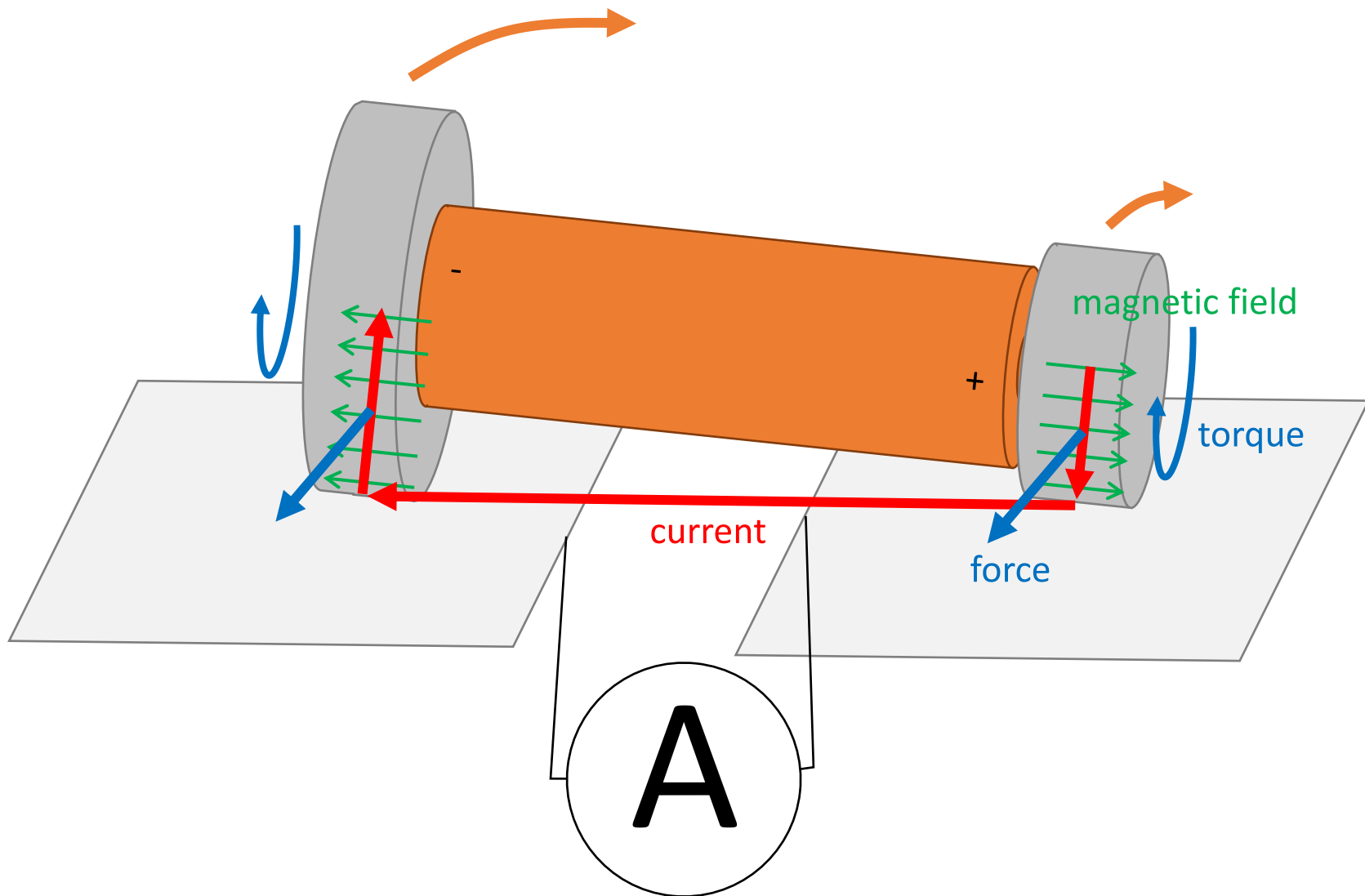

How wheels move carts - rolling

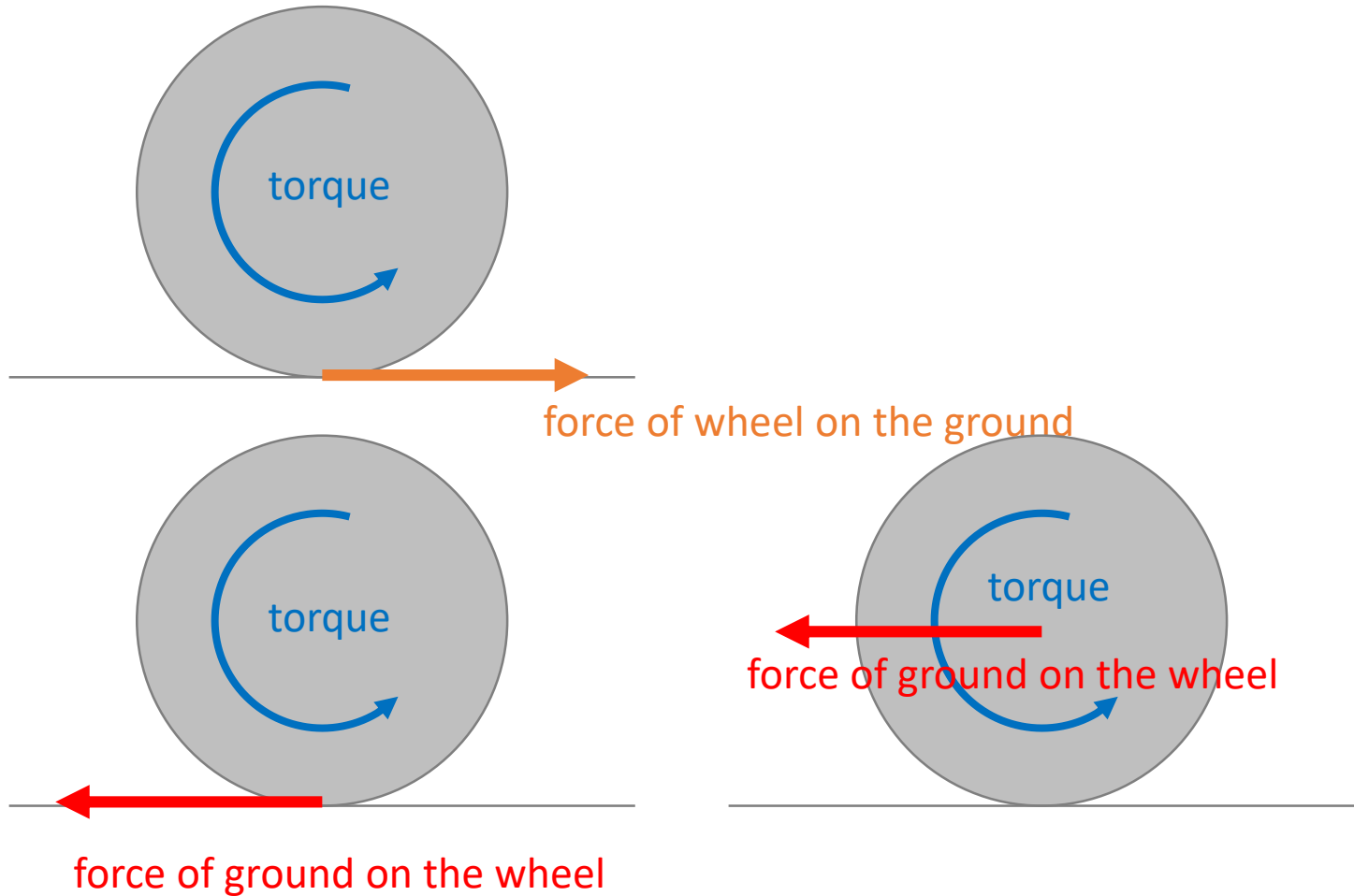

How wheels move carts - sliding

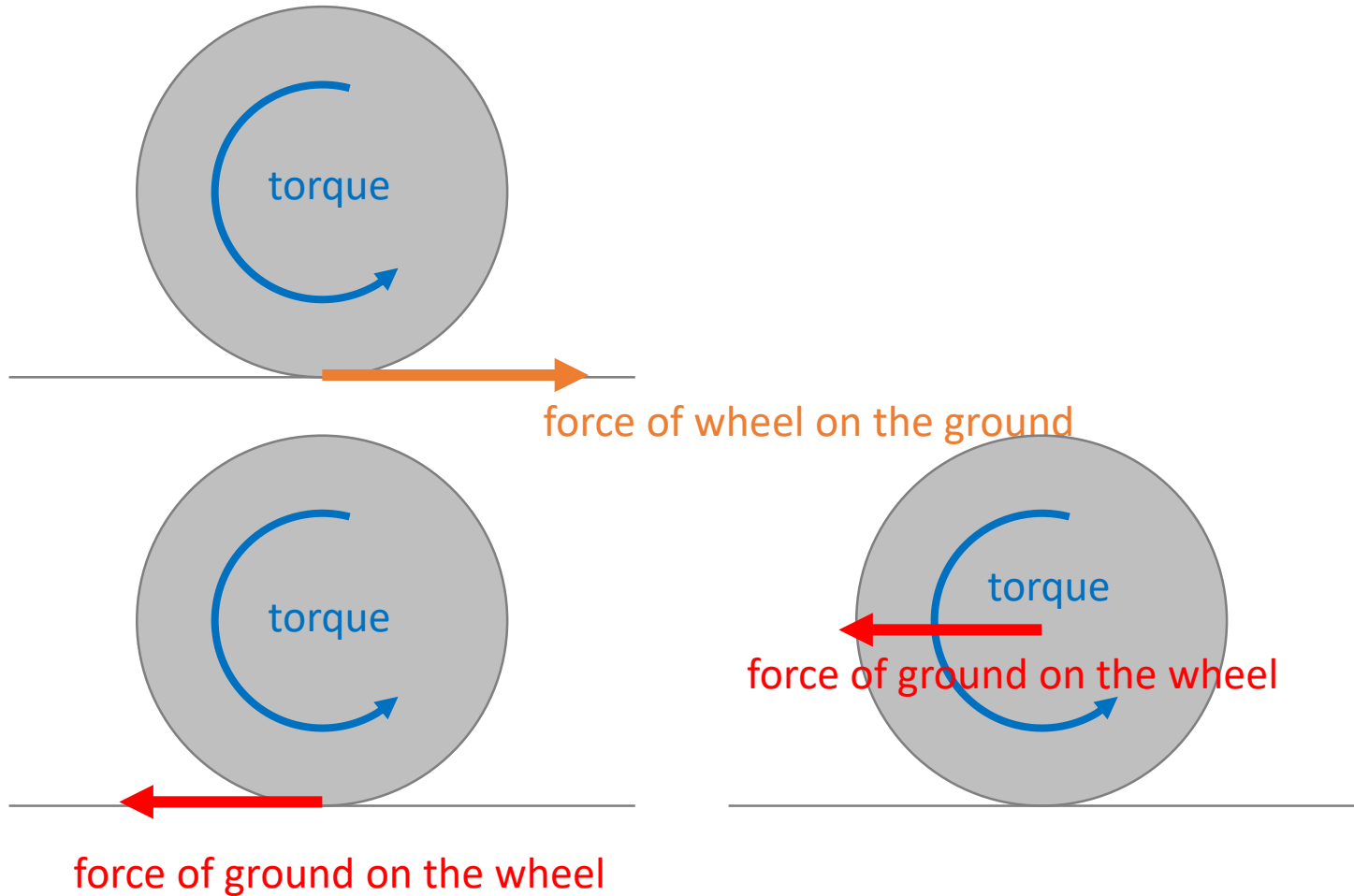

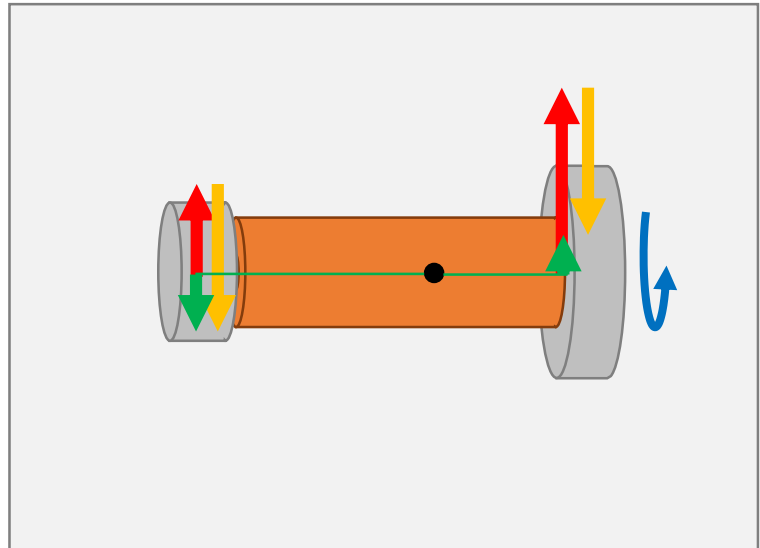
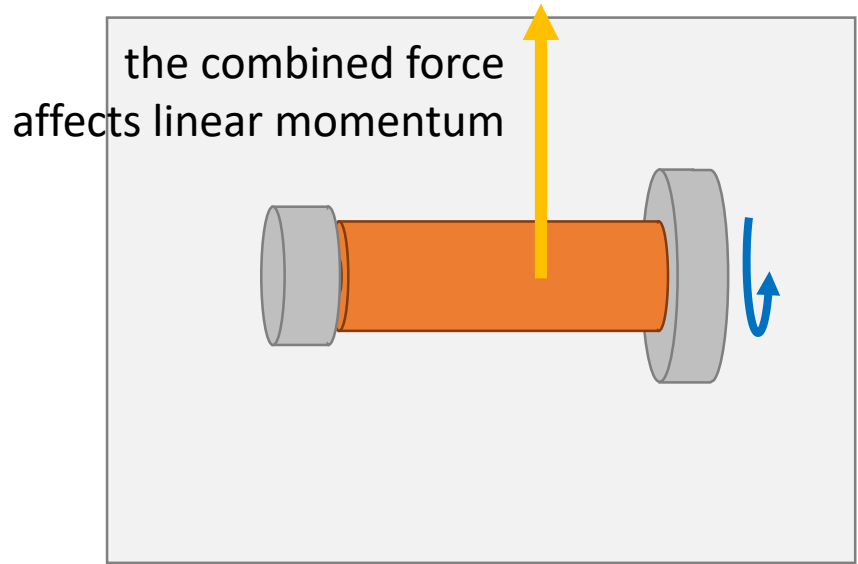
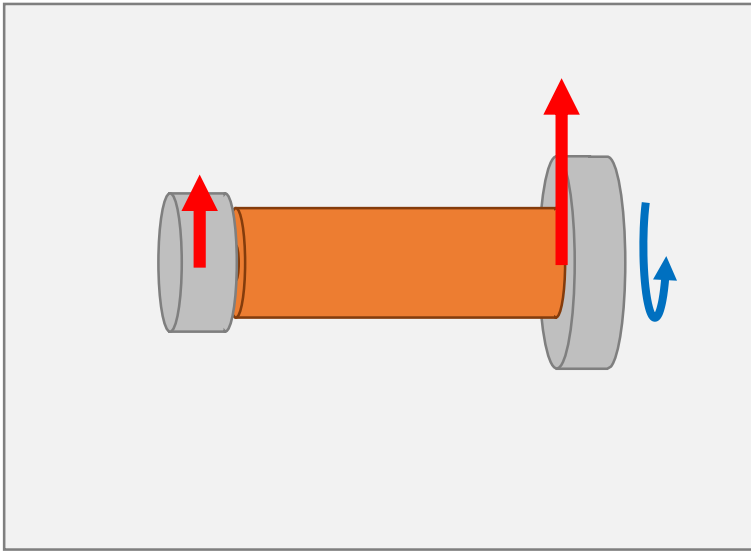

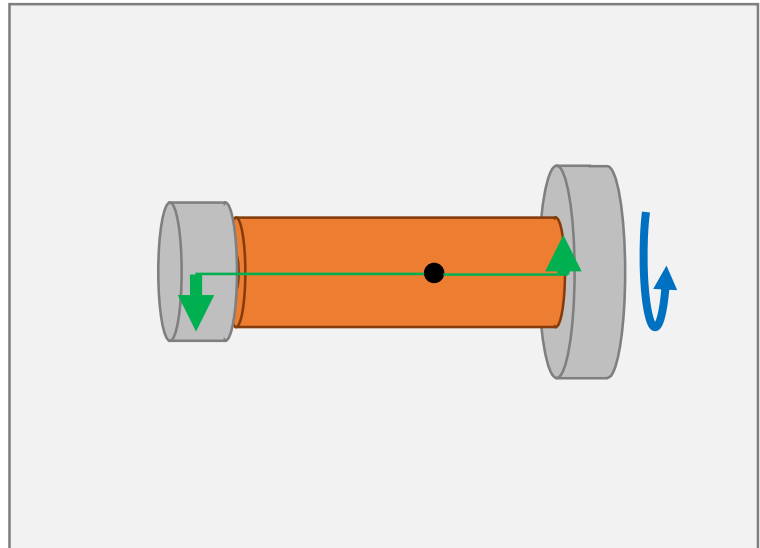
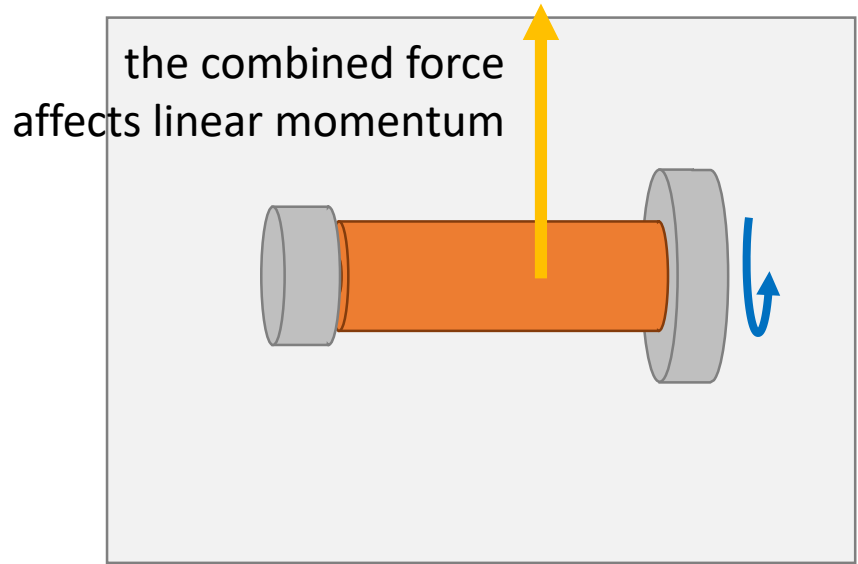
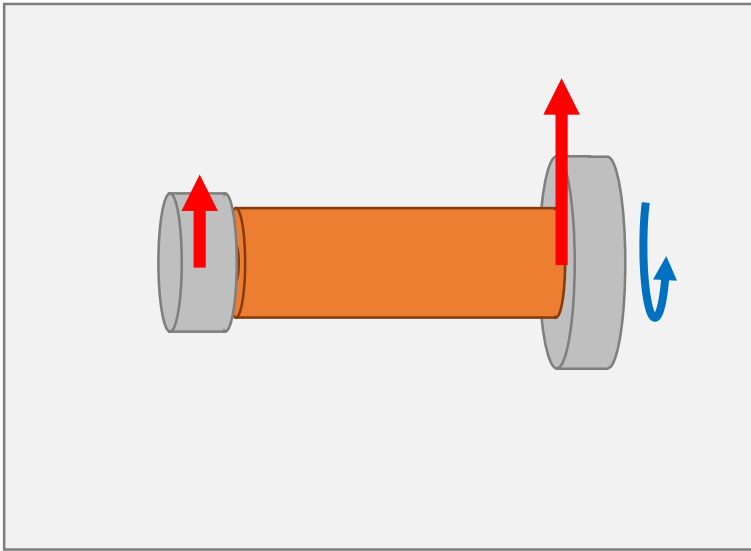

The qualitative explanation

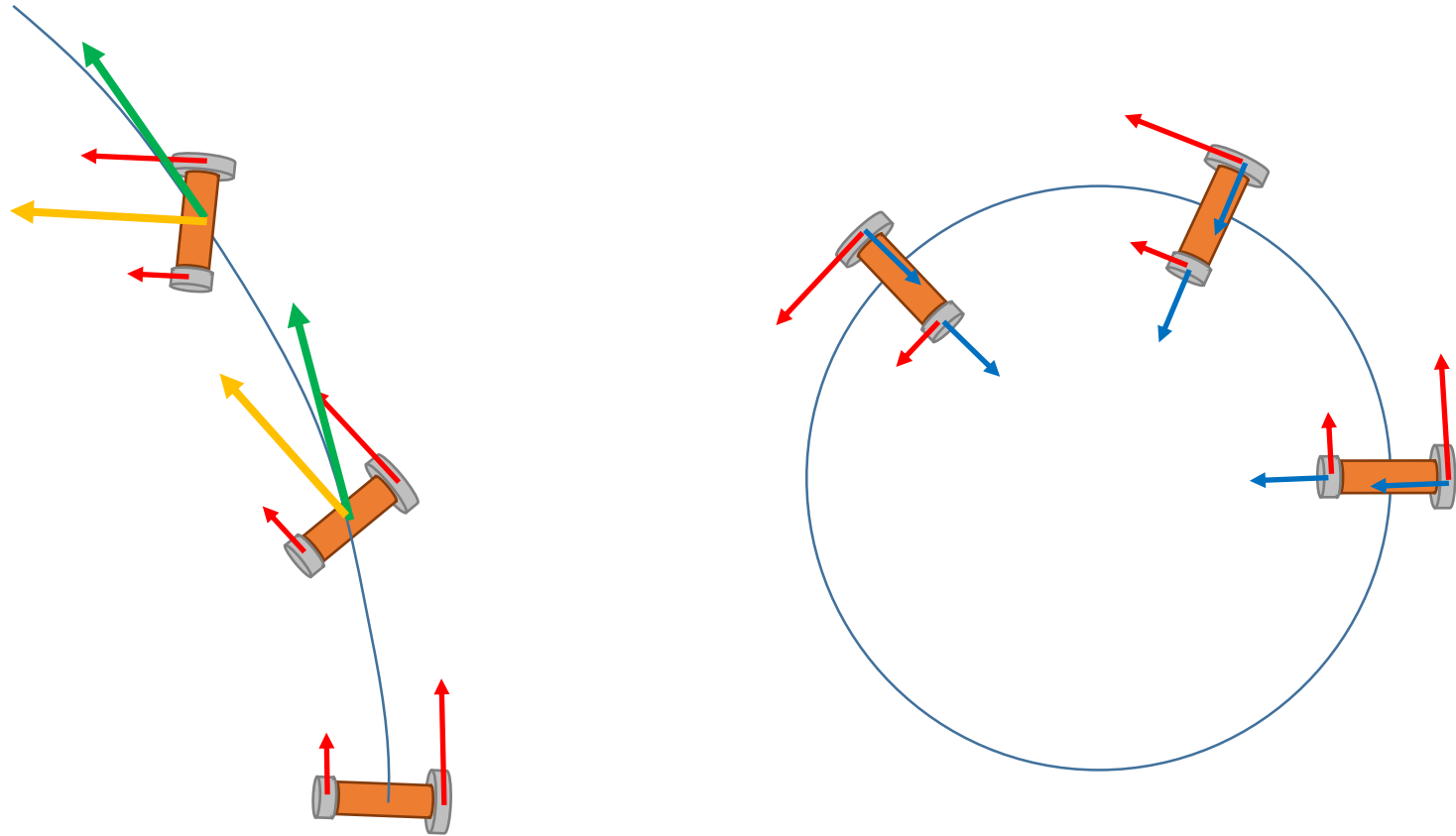

The qualitative explanation

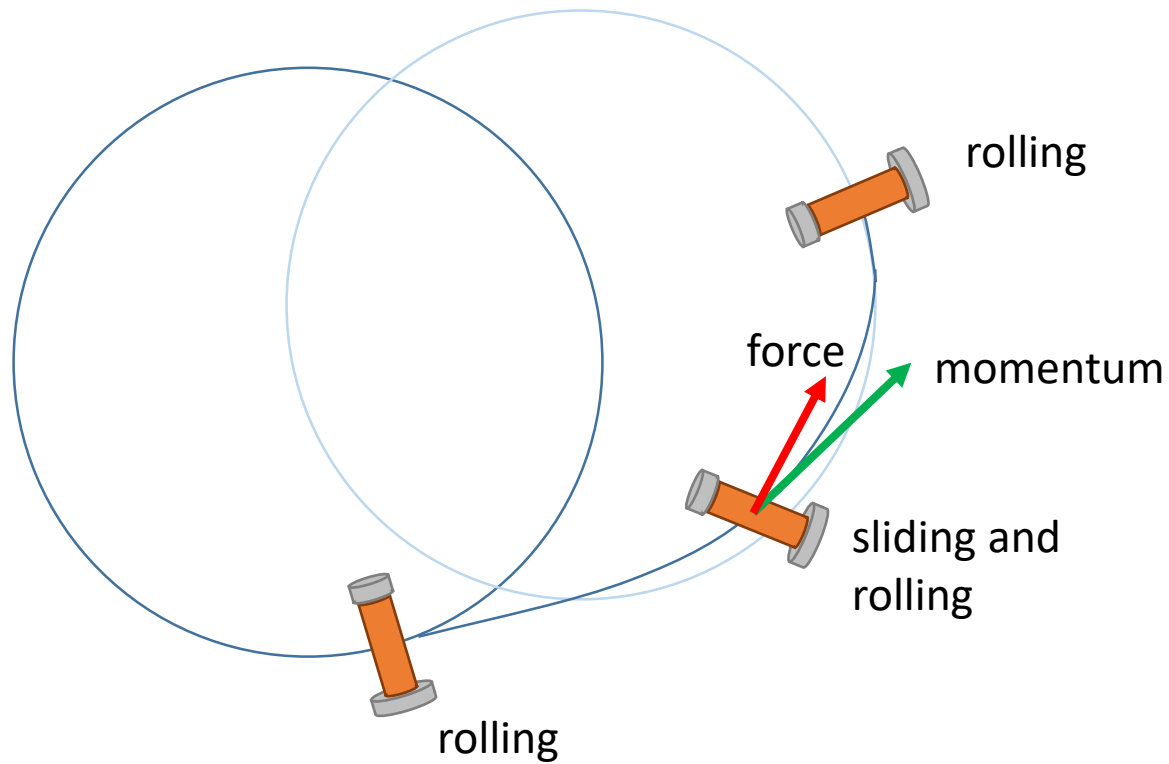

The qualitative explanation

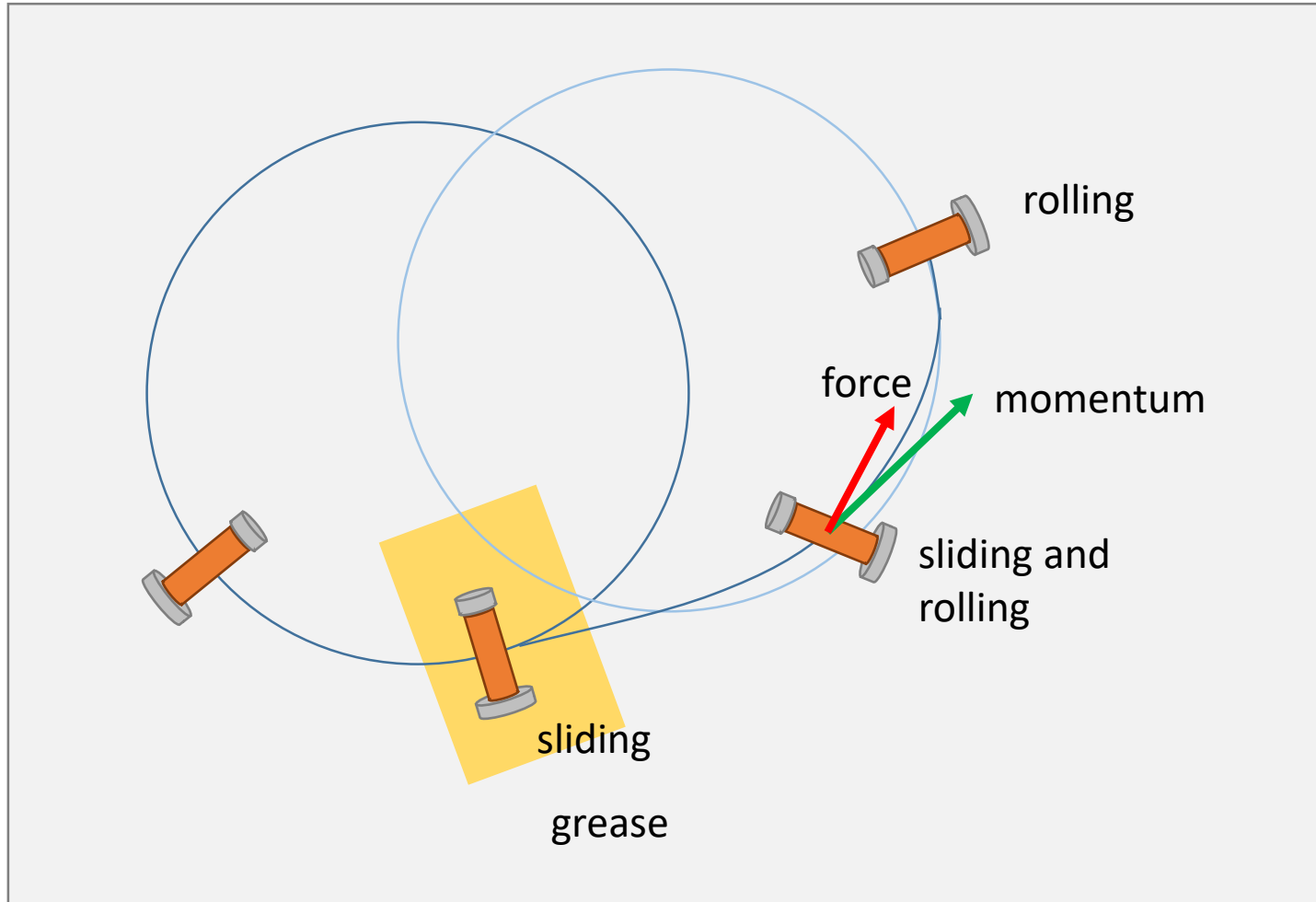

Possible parameters to investigate

